

JVC[®]

COLOUR VIDEO CAMERA

TK-C1430

INSTRUCTIONS

TK-C1431



These are general IMPORTANT SAFEGUARDS and certain items may not apply to all appliances.

IMPORTANT SAFEGUARDS

1. Read all of these instructions.
2. Save these instructions for later use.
3. All warnings on the product and in the operating instructions should be adhered to.
4. Unplug this appliance system from the wall outlet before cleaning. Do not use liquid cleaners or aerosol cleaners. Use a damp cloth for cleaning.
5. Do not use attachments not recommended by the appliance manufacturer as they may cause hazards.
6. Do not use this appliance near water - for example, near a bathtub, washbowl, kitchen sink, or laundry tub, in a wet basement, or near a swimming pool, etc.
7. Do not place this appliance on an unstable cart, stand, or table.
The appliance may fall, causing serious injury to a child or adult, and serious damage to the appliance.

PORTABLE CART WARNING
(symbol provided by RETAC)



S3125A

Use only with a cart or stand recommended by the manufacturer, or sold with the appliance. Wall or shelf mounting should follow the manufacturer's instructions, and should use a mounting kit approved by the manufacturer. An appliance and cart combination should be moved with care.

Quick stops, excessive force, and uneven surfaces may cause the appliance and cart combination to overturn.

8. Slots and openings in the cabinet and the back or bottom are provided for ventilation, and to insure reliable operation of the appliance and to protect it from overheating, these openings must not be blocked or covered. The openings should never be blocked by placing the appliance on a bed, sofa, rug, or other similar surface.

This appliance should never be placed near or over a radiator or heat register. This appliance should not be placed in a built-in installation such as a bookcase unless proper ventilation is provided.

9. This appliance should be operated only from the type of power source indicated on the marking label. If you are not sure of the type of power supplied to your home, consult your dealer or local power company. For appliance designed to operate from battery power, refer to the operating instructions.
10. This appliance system is equipped with a 3-wire grounding type plug (a plug having a third (grounding) pin). This plug will only fit into a grounding-type power outlet. This is a safety feature. If you are unable to insert the plug into the outlet, contact your electrician to replace your obsolete outlet. Do not defeat the safety purpose of the grounding plug.

11. For added protection for this product during a lightning storm, or when it is left unattended and unused for long periods of time, unplug it from the wall outlet and disconnect the antenna or cable system. This will prevent damage to the product due to lightning and power-line surges.
12. Do not allow anything to rest on the power cord. Do not locate this appliance where the cord will be abused by persons walking on it.
13. Follow all warnings and instructions marked on the appliance.
14. Do not overload wall outlets and extension cords as this can result in fire or electric shock.
15. Never push objects of any kind into this appliance through cabinet slots as they may touch dangerous voltage points or short out parts that could result in a fire or electric shock. Never spill liquid of any kind on the appliance.
16. Do not attempt to service this appliance yourself as opening or removing covers may expose you to dangerous voltage or other hazards. Refer all servicing to qualified service personnel.
17. Unplug this appliance from the wall outlet and refer servicing to qualified service personnel under the following conditions:
 - a. When the power cord or plug is damaged or frayed.
 - b. If liquid has been spilled into the appliance.
 - c. If the appliance has been exposed to rain or water.
 - d. If the appliance does not operate normally by following the operating instructions. Adjust only those controls that are covered by the operating instructions as improper adjustment of other controls may result in damage and will often require extensive work by a qualified technician to restore the appliance to normal operation.
 - e. If the appliance has been dropped or the cabinet has been damaged.
 - f. When the appliance exhibits a distinct change in performance - this indicates a need for service.
18. When replacement parts are required, be sure the service technician has used replacement parts specified by the manufacturer that have the same characteristics as the original part. Unauthorized substitutions may result in fire, electric shock, or other hazards.
19. Upon completion of any service or repairs to this appliance, ask the service technician to perform routine safety checks to determine that the appliance is in safe operating condition.

Safety Precautions

Due to design modifications, data given in this instruction book are subject to possible change without prior notice.

WARNING:
TO REDUCE THE RISK OF FIRE OR ELECTRIC SHOCK, DO NOT EXPOSE THIS APPLIANCE TO RAIN OR MOISTURE.

AVERTISSEMENT:
POUR EVITER LES RISQUES D'INCENDIE OU D'ELECTROCUTION, NE PAS EXPOSER L'APPAREIL A L'HUMIDITE OU A LA PLUIE.

Thank you for purchasing this product.

(These instructions are for TK-C1430E and TK-C1431EG)

Before beginning to operate this unit, please read the instruction manual carefully in order to make sure that the best possible performance is obtained.

CONTENTS

INTRODUCTION

Features	6
Operating Precautions	7
Controls, Connectors and Indicators	8

CONNECTION/INSTALLATION

RM-P2580 System	12
Procedures	14
Mounting the lens	15
Installing the ferrite core	16
Connections on the back	16
Mounting the camera	18
Lens adjustment	20
Back focus adjustment	21
Auto white balance control adjustment	22

MENU SETTING

Setting the menu	23
The flow of menu screen	24
SYNC ADJUST Screen	26
ALC SETTINGS Screen	26
VIDEO ADJUST Screen	31
MODE SELECT Screen	32
MOTION DETECT Screen	34
COMMUNICATION Screen	35
MAINTENANCE Screen	35
FACTORY SETTINGS Screen	35
BLC EDITTING Screen	36
Manual Adjustment of White Balance	37
CAMERA TITLE Setting	38
Setting the MOTION DETECT Function	39
Output of Black-White/Colour switching signal	40
Control by Black-White/Colour switching signal from the outside	41
White spot compensation	42

OTHERS

Specifications	43
----------------------	----

INTRODUCTION

Features

- A DSP (Digital Signal Processor) features a Extended Dynamic Range (ExDR) and enables to shoot both bright and dark locations.
 - The use of a CCD with a SENSE UP (X32) function realized the minimum luminous flux density for subject of 0.9 lx (F1.2, 50%, AGC 20dB) and 0.03 lx (at SENSE UP (X32)). Furthermore, we realized 0.03 lx (F1.2, 50% AGC 20dB) thanks to the function of B/W mode.
 - A motion detector function detects the motion inside an image and emits alarm signals.
 - The equipped Y/C terminals and RS-422A/RS-485 terminals allow intended compatibility with diversified systems.
 - Day/Night surveillance
When the light is low, the camera pictures can be switched automatically to black and white pictures.
 - Electronic zoom
The 10x electronic zoom allows monitoring in far greater detail.
- Before starting an important recording, be sure to perform a test recording in order to confirm that a normal recording is possible.
 - We do not accept liability for the loss of a recording in the case of it becoming impossible to record due to a problem in the video camera, VCR or video tape.
 - We do not accept liability for any damage to the camera in cases where it is dropped because of bad installation due to failure to observe the installation instructions correctly. Please be careful when installing the camera.
 - The motion detector is not a feature which prevents theft, fire, etc. Even if an accident should occur resulting in damage, we do not accept any liability.

Characters and symbols used in this instruction manual.

CAUTION : Cautionary notes concerning operation of the unit.

MEMO : Reference such as restrictions of features, etc.

 : Reference page or item.

Operating Precautions

- To save energy, when it is not being used turn the system's power off.
 - This camera has been designed for indoor use. When you use it outdoors, be sure to use a housing or the like.
 - Do not install or use the camera in the following places.
 - In a place exposed to rain or moisture.
 - In a place with vapor or oil soot, for example in a kitchen.
 - When the ambient temperature rises above or falls below the acceptable range (from -10°C to 50°C).
 - Near a source of radiation, X-rays, strong radio waves or magnetism.
 - In a place subject to vibration.
 - In a place with excessive dirt.
 - If this camera and the cables connected to this camera are used where there are strong electromagnetic waves or where there is magnetism present, for example near a radio or TV transmitter, power transformer or an electric motor, the picture may produce noise and the colours may be affected.
 - This camera incorporates an AGC circuit. As a result, when it is used under low light conditions, the camera sensitivity is automatically boosted and the picture may look uneven. However, this is not a malfunction.
 - While the AGC is activated, if transceiver which causes strong electromagnetic wave is at close distance, picture might suffer from beat.
So please use the camera more than three meters from such transceivers.
 - When this camera is used in the ATW mode, the recorded colours may be slightly different from the actual colours due to the operational principles of the auto-tracking white balance circuit. However, this is not a malfunction.
 - If a high-intensity object (such as a lamp) is shot, the image on the screen may have vertical lines (smear) or blur (blooming) at its periphery. This is a characteristic of the CCD, and is not a defect.
 - Observe the following when carrying out camera maintenance.
 - Turn the power OFF before proceeding to carry out maintenance.
If it is contaminated seriously, clean the contaminated part with a cloth (or a tissue) which has been soaked in a solution of water and a neutral detergent.
 - The unit is to be powered by a DC 12 V or an AC 24 V power supply. (TK-C1430E) The AC 24 V power supply should conform to the following: Isolated power supply only
TK-C1431EG: Connect the power cable to the commercial power supply of 220V – 240V.
 - Caution for operating the video iris lens.
If the video iris lens is set to an extremely low level, a malfunction – such as the hunting phenomenon where the iris opens and closes in voluntary – can occur.
In such a case, first set the “LEVEL” potentiometer on the lens to the H position (iris open), and then adjust it to an optimum level. (☞ page 20)
 - The cable stopper on the terminal block can come off sometimes. Therefore, be sure to take enough time and fix the cable securely.
 - When a highly bright subject is shot, sometimes undulations can be observed on the vertical lines of the subject. However, this phenomenon is peculiar to the unit and is not a sign of malfunction.
 - The beat may sometimes appear on the screen if gain is raised when the line lock is in use, but the phenomenon takes place due to the fluctuation of power frequency and is not a malfunction.
 - You may hear some noise when the screen is switched between the colour and the black and white mode, because the optical filter moves. Also, black vertical bands will appear on the screen.
 - Set the Iris Selector switch to VIDEO to use the manual lens.
-

INTRODUCTION

Controls, Connectors and Indicators

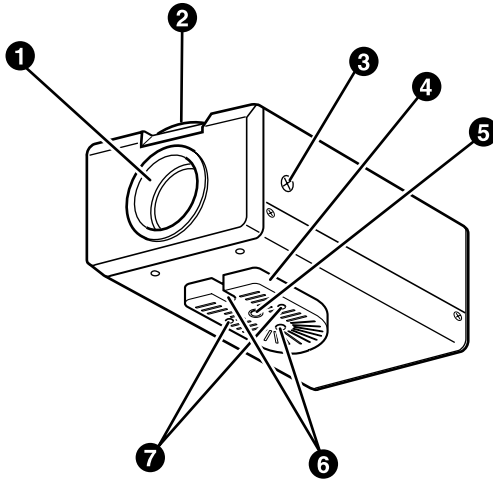

1 Lens mount

To attach the lens.

This is applicable to both C-mount lenses and CS-mount lenses.

2 Back focus adjustment ring

Adjusting the back focus during lens installation.

When readjustment is required, loosen the locking screw 3 by turning it counterclockwise and turn the back focus adjustment ring 2.

After the adjustment, tighten the locking screw 3 again.

3 [BF LOCK] Back focus locking screw

This serves to fix the back focus-adjusting ring.

4 Camera-mounting bracket

The bracket has been attached on the bottom of the camera before shipment. It can also be attached on the top according to the circumstance.

To re-attach the bracket use the threaded holes at the top, with the camera mounting bracket fixing screws 7.

5 Camera-mounting screw hole (1/4 inch)

Use this hole when mounting the camera onto a fixer, pan/tilt unit, and the like. (Use a screw shorter than 7 mm.)

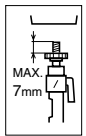

6 Rotation-preventive hole

Make use of this rotation-preventive hole to prevent any fall when mounting the camera. Always make sure that the camera is securely mounted.

7 Camera mounting bracket fixing screws (x2: M2.6 x 6 mm)

Be sure to use a 6 mm long screw.

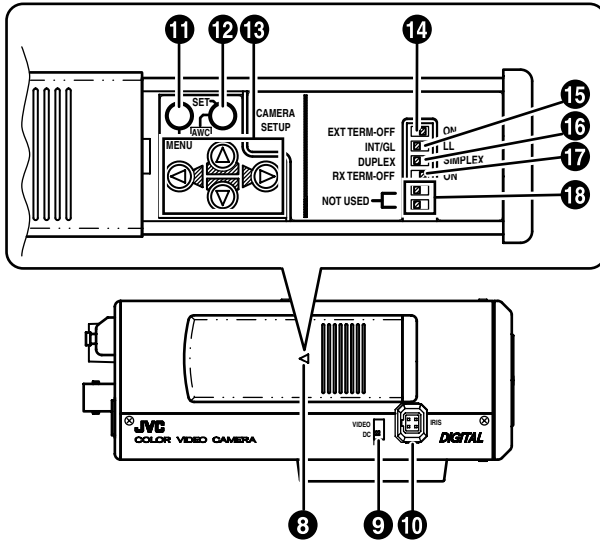

8 Cover

The cover slides open when push to the left.

9 [VIDEO/DC] Iris Selector Switch

This should be set according to the type of lens if an automatic iris control lens is used.

VIDEO: In case of lens with EE amp built-in.

DC: In case of lens without EE amp built-in.

(DC: At time of factory shipment)

10 [IRIS] Iris Terminal

This is connected to an automatic iris control lens.

(☞ Page 15)

11 [MENU] Menu Button

When pressed, a menu screen is brought up.

(☞ Page 23)

12 [SET/AWC] Set. Auto White Control Button

SET: Press this button to display a sub-menu.

(☞ Page 23)

AWC: If this button is kept pressed for more than 1 second, a one-push-auto-white-balance function works and sets the white balance. Once it is set, even if colour temperature changes, white balance does not change. It is also possible to make fine adjustments on the set white balance.

(☞ Page 22)

INTRODUCTION

Controls, Connectors and Indicators (Continued)

13 [▲, ▼, ◀, ▶] Up-and-down, left-and-right Button

These buttons select items on the menu screen and change a set value.

(☞ Page 23)

14 [EXT.TERM-ON/OFF] Terminal On/Off Switch of External Synchronization Signal

This is a terminating ON/OFF switch for the external synchronization input signal. When this is switched ON, termination is executed via a 75 Ω resistor.

ON: terminates at 75Ω.

OFF: does not terminate at 75Ω.

(ON: At time of factory shipment)

15 [INT/GL, LL] Selector Switch for Synchronizing System

This switch sets the synchronizing system for the camera.

INT/GL:

This is set for internal synchronization (INT) or external synchronization (GL).

LL (Line Lock):

The camera's vertical synchronization is locked to the AC power line frequency.

When switching between multiple cameras using a switcher, selecting this mode and adjusting the vertical phase can reduce the monitor sync disturbances occur that when the camera image is switched. (This cannot be used in regions where the power frequency is 60 Hz) (INT/GL: At time of factory shipment)

16 [DUPLEX, SIMPLEX] Selector Switch for Transmission System

If the setting is changed, be absolutely sure to switch on the power again.

DUPLEX:

This switch sets to DUPLEX when the transmission between the camera and a remote control unit is in a duplex system (two-way).

SIMPLEX:

This switch sets to SIMPLEX when the transmission between the camera and a remote control unit is in a simplex system (one-way).

(DUPLEX: At time of factory shipment)

17 [RX.TERM-ON/OFF] RX Signal Terminal ON/OFF Switch

This sets whether or not the signal between RX + and RX – on the back 20 should be terminated at the value of 110Ω resistance.

ON: Terminated.

OFF: Not terminated.

If the system including the camera is the M.DROP (Multi-drop, RS-485) system, only the last camera mounted along the control signal cable is set to "ON" and the other cameras are set to "OFF". In case of the M.DROP system, it becomes necessary to set the Machine ID. (☞ Page 35)

If the system including the camera is the P TO P (Point to Point, RS-422A) system, set this switch of all the cameras to "ON". The item STYLE on the COMMUNICATION screen sets M.DROP or P TO P (☞ Page 35)

(ON: At time of factory shipment)

18 NOT USED

This cannot be used. Do not switch.

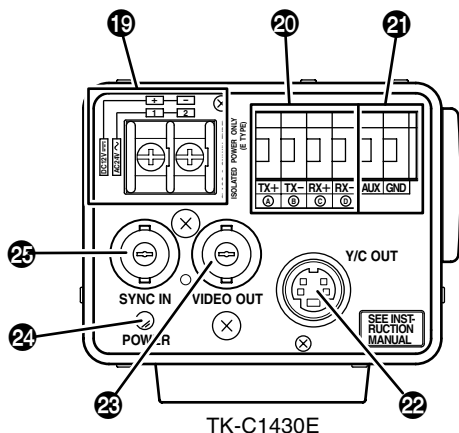

TK-C1430E

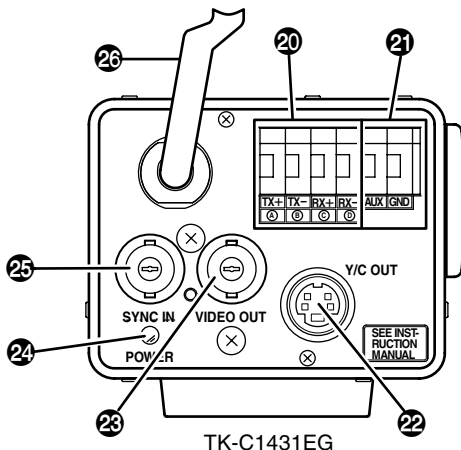

TK-C1431EG

19 [DC 12V, AC 24V] Power input terminals (TK-C1430E)

To input DC 12V or AC 24V power.

20 [TX+Ⓐ, TX-Ⓑ, RX+Ⓒ, RX-Ⓓ] Control signal connection terminals

Terminals for inputting signals with electrical characteristics conforming to the EIA/TIA RS-422A or RS-485 standard.

☞ **17** RX.TERM switch

21 [AUX, GND] Auxiliary Input/Output Terminals

If there is any change in the area set on the MOTION DETECT screen, these terminals output the corresponding signals. (☞ Page 34)

These terminals also output the B&W/COLOUR signal. (☞ Page 30)

[Open-collector low signal. Maximum voltage 30V, current 30mA.]

When carrying out B&W/COLOUR switching using the control signal, the signals are input through these terminals. (☞ Page 30)

[B&W: make; COLOUR: break]

22 [Y/C OUT] Y/C output connector

This 4-pin connector outputs the luminance and chrominance signal.

- Pin configuration of Y/C OUT connector



Pin No.	Signal
1	GND
2	GND
3	Luminance (Y)
4	Chrominance (C)

23 [VIDEO OUT] Video signal output connector

This BNC connector outputs a composite video signal. Connect this to the video input connector of a video monitor, switcher, etc.

24 [POWER] Power indicator lamp

This lamp lights when power is supplied to the camera.

25 [SYNC IN] Sync signal input connector

This BNC connector accepts the input of an external sync signal such as a composite video (VBS) or black burst (BB) signal.

When a sync signal is input into this connector, the camera operation is automatically synchronized with the external sync signal.

To terminate this connector at 75Ω, turn ON the EXT.TERM switch **14**.

26 Power cable (TK-C1431EG)

Connect to the commercial AC (220V – 240V) outlet.

CONNECTION/INSTALLATION

RM-P2580 System

■ System with up to 8 cameras

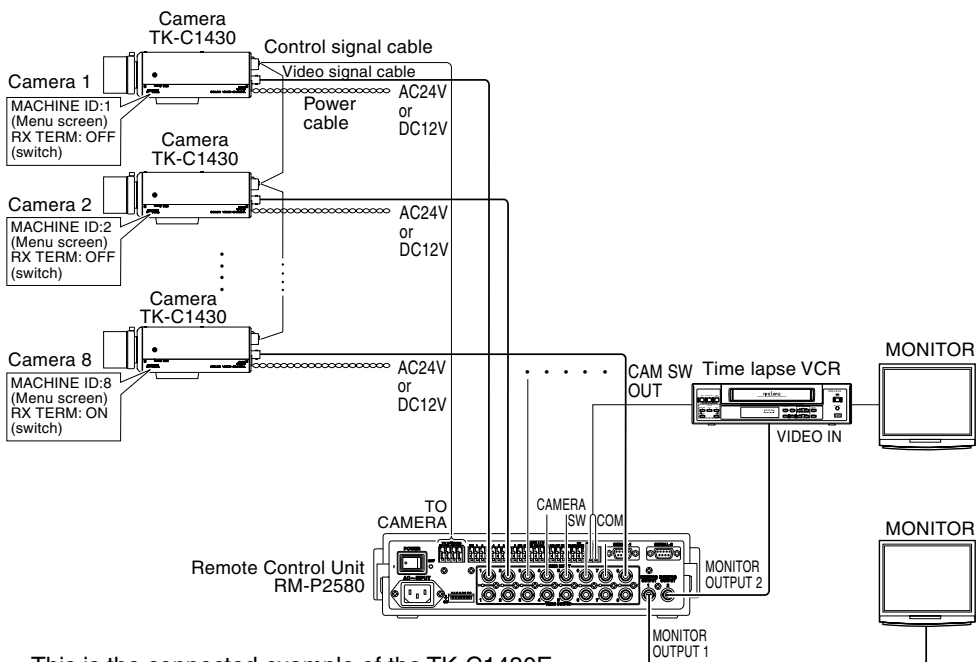

This is the connected example of the TK-C1430E.

When controlling with any system except the RM-P2580, execute proper settings using switches and menu screens according to the systems used. (Page 14)

MEMO

- When operating a system using the RM-P2580, several cameras (up to 16) can be connected and used on one control signal cable. Consequently, an incorrect switch setting on just a single camera will cause the entire system to work incorrectly.
- Confirm switch settings on the screen as follows.
 - ① Confirm that the image from the camera to be checked is displayed on the monitor.
 - ② Turn OFF and then ON the AC power to the camera to be checked.
 - ③ The camera begins the initial operation and characters similar to those shown in the illustration on the right appear on the monitor screen.
 - ④ Confirm that "DUPLEX" and "ID-□□" are displayed and that the ID number is the correct number (the number should be the same as the number of the VIDEO INPUT terminal to which the camera is connected on the rear panel of the RM-P2580).
 - ⑤ If wrong, set the camera ID again.

MONITOR screen
(example showing camera ID as "05")

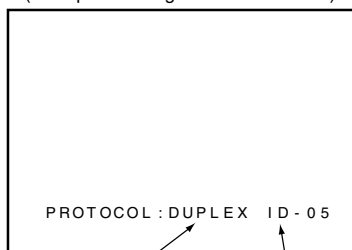

"DUPLEX" should be displayed.

The number shown in the □□ part of ID-□□ should be correct.

■ Connecting the control signal cable

(Use a twisted-pair cable for connection. Page 17.)

Camera 1

control signal
connection terminals

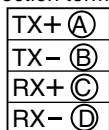

RM-P2580

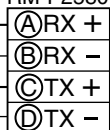

Camera 2
control signal
connection terminals

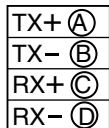

Connect:

Camera TX+ to RM-P2580 RX+

Camera TX- to RM-P2580 RX-

Camera RX+ to RM-P2580 TX+

Camera RX- to RM-P2580 TX-

The (A) (B) (C) (D) marks indicated on both the camera terminals and the RM-P2580 terminals facilitate correct connections. Connect the terminals with identical marks.

■ Setting the switches Page 10)

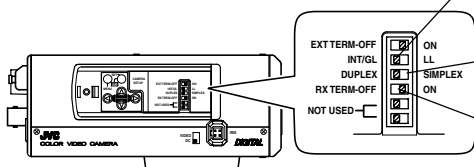

Select the synchronization method of the camera image.

Set the switch on all cameras to LL (Line Lock) and match with the V. PHASE.

(Page 26.)

Set this switch to the DUPLEX

* If the setting is changed, be absolutely sure to switch on the power again.

Set this switch to ON (signal termination ON) only on the camera placed at the end of the control signal cable.

Set to OFF on all other cameras.

■ Setting on the MENU screen Page 35)

* If the setting is changed, escape from the menu screen once, and definitely switch on the power again.

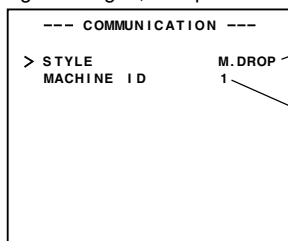

Set to M.DROP

Set to M.DROP when the RM-P2580 is used as a remote control unit. When controlling from another machine, make sure that it matches the communication system used.

MACHINE ID setting switches

Set this item to match the RM-P2580 VIDEO INPUT terminal number for each camera.

When connecting

- Turn OFF the power supply to all equipment to be used before making connections.
- Carefully read the Instructions for each piece of equipment to be used before making connections.
- For the appropriate connection cables and the length of these, carefully read "Connections on the back" on page 16.
- The control signal cable cannot be used for loop connection.

CONNECTION/INSTALLATION

Procedures

Execute connection/installation according to the procedures described below.
Turn OFF the power supply to all equipment to be used before making carefully.

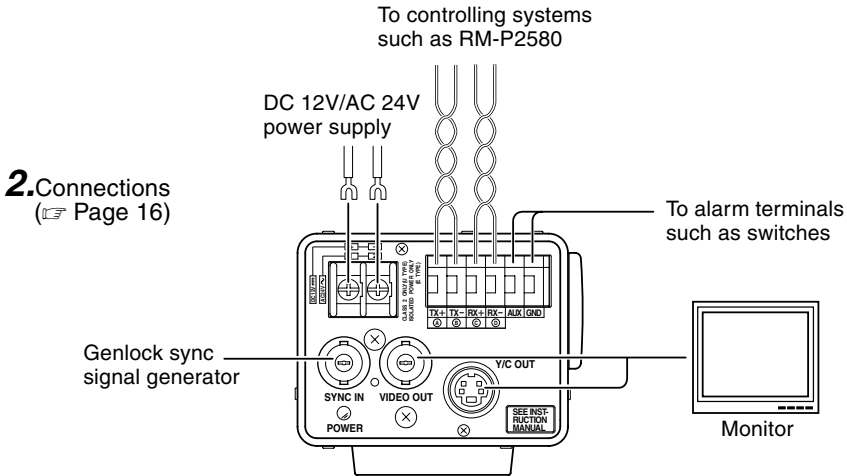
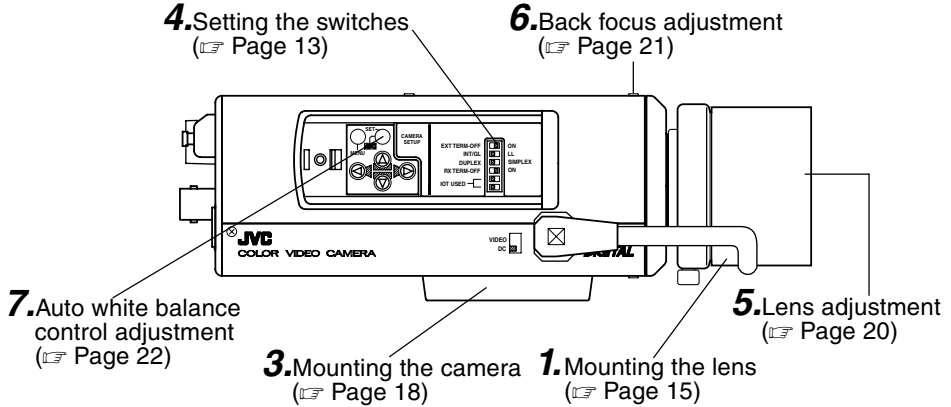

This is the connected example of the TK-C1430E.
TK-C1431EG ☞ Page 17

Mounting the lens

Mount the lens according to the procedures described below.

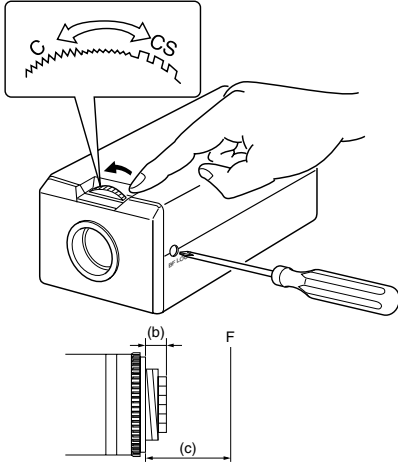

1. Before mounting a lens, check whether it is a C-mount or CS-mount lens. To change the mounting method, loosen the back-focus locking screw (M 2.6) using a Phillips head screwdriver, turn the back-focus adjusting ring with your fingers or the screwdriver and change the mounting method. As regards the dimension (b) of the area to which the lens is to be installed as illustrated on the left diagram, use the one with less value than what's shown in the table below. For both the C-mount and CS-mount, never use whatever exceeds the dimension (b), as such will not allow normal installation and damage the inner part of the camera, resulting in a malfunction.

Lens	Flange back (c)	Dimension (b)
C mount lens	17.526mm	5.5mm or less
CS mount lens	12.5mm	5.5mm or less

The F mark indicates a focal point.

2. Mount the lens on the camera by turning the lens clockwise. Adjust its position.
3. When using an auto-iris lens with an EE amplifier, turn the switch to the "VIDEO" side. When no EE amplifier is equipped, turn the switch to the "DC" side.
4. If the lens has an auto-iris mechanism, connect the lens cable after checking the pin arrangement. If the lens cable has a different type of plug, use the 4-P plug supplied.

CAUTION:
Always attach the ferrite core (supplied) to the lens cable. (Page 16)

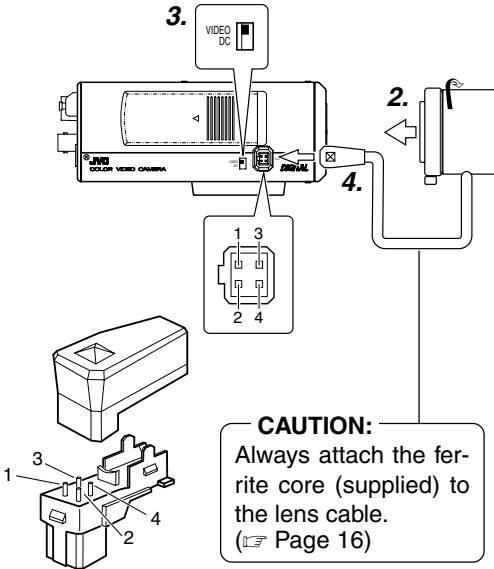

Attached 4 pin plugs

Pin No.	Lens	DC IRIS (does not contain EE amplifier)	VIDEO IRIS (contain EE amplifier)
1		Brake ⊖	9V [max 50mA]
2		Brake ⊕	NC
3		Drive ⊕	VIDEO
4		Drive ⊖	GND

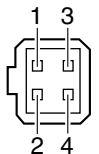

CONNECTION/INSTALLATION

Installing the ferrite core

To retain electromagnetic compatibility, use the ferrite cores provided when connecting to the lens.

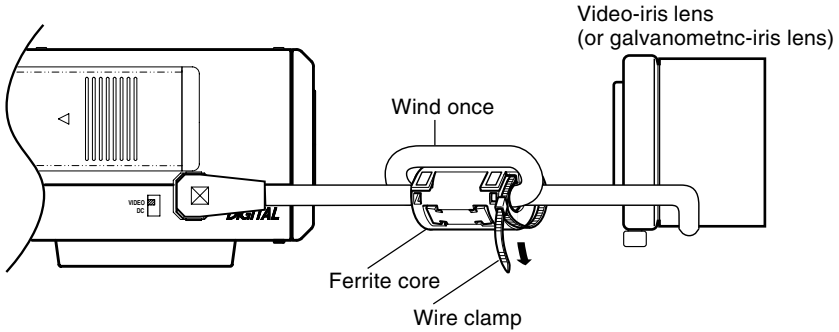

Notes:

- Install the ferrite cores within 50 mm of the camera-side connectors. (Fasten the ferrite core with the wire clamp provided.)
- If the LENS cable is short, please connect the cable to the camera without winding the cable around the ferrite core.

Connections on the back

■ Power supply TK-C1430E (DC 12 V or AC 24V)

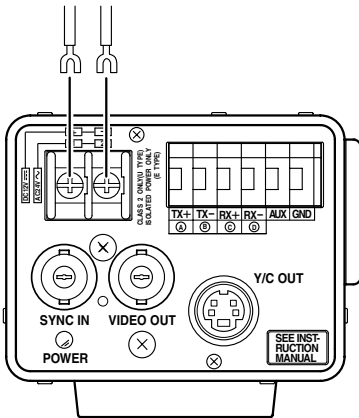

Connect the DC 12 V or the AC 24 V power supply to the DC 12V/AC 24V terminals. To prevent connection errors or a cable disconnection, we recommend the use of lug plates for the connections.

The following table shows the connection distances and connection cables provided that 2-conductor VVF cables (vinyl-insulated vinyl sheath cables) are used.

Maximum extension (reference)	100 m	260 m	410 m	500 m
Conductor diameter	1.0Ømm and more	1.6Ømm and more	2.0Ømm and more	2.6Ømm and more

MEMO

- If thin cables are used (i.e. with a high resistance), a significant voltage drop will occur when the unit is at its maximum power consumption. Either use a thick cable to restrict the voltage drop at the camera side to below 10%, or place the power supply near to the camera. If voltage drop occurs during operation, the performance will be unstable.
- Attach the cable conductors so that they do not come into contact with the drop prevention wires.
- Do not allow input from both a DC 12 V and AC 24 V power supply at the same time.
- When using a DC 12 V power supply, ensure that the polarities of the cable are correct.
- The AC 24 V power supply should conform to the following: Isolated power supply only

TK-C1431EG (AC220V – 240V)

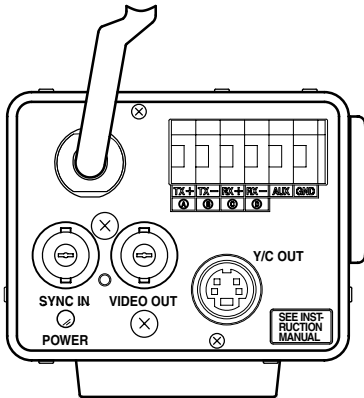

Power cable connect to the commercial AC220V – 240V outlet

CAUTION:

When you use this camera, the socket-outlet shall be installed near equipment so as to disconnect easily.

■ Control signal cables

These cables should be connected only when it is required to control the camera using the RS-442A or RS-485 signals. The use of 0.65 4-conductor twisted pair cables is recommended. With these cables, the maximum extension distance is 1,200 m.

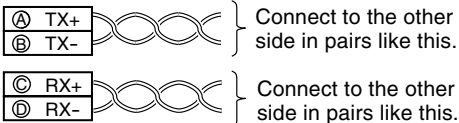

■ Genlock connection

With some systems, when the external sync signal is a composite video or black burst signal genlocking by applying an external sync input requires the horizontal phase (H PHASE) and colour phase (SC COARSE) to be adjusted.

MEMO

- Genlocking is not possible with a signal containing too much jitter, such as a VCR or videodisc playback signal.
- For details, consult a JVC authorized dealer.

CONNECTION/INSTALLATION

Mounting the camera

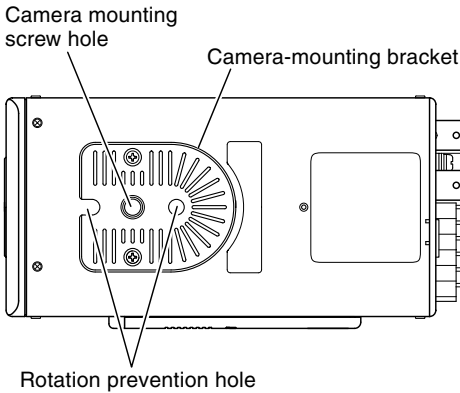

When mounting the camera on a fixer, pan/tilt, etc., use the camera mounting screw hole located on the camera-mounting bracket.

CAUTION:

Use the screw with a length shorter than 7mm from a camera-mounting face.

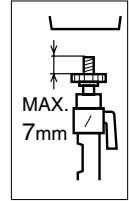

Furthermore, make use of the rotation prevention hole to prevent the camera from falling and securely mount the camera.

Special precautions must be taken for mounting the camera on a wall or a ceiling. We are not liable for any damage caused by improper installation.

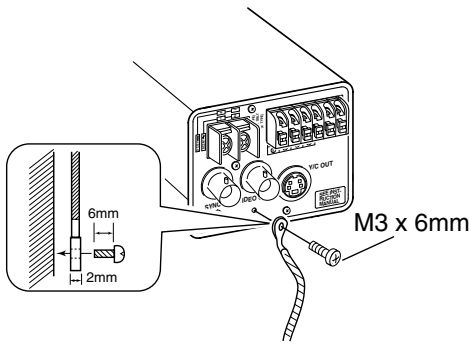

Fall Prevention

- Exercise maximum caution when installing the unit to the wall or ceiling. You should not engage in the installation work yourself. Ask a professional to do the job, since the fall of the unit can result in injuries and accidents.
- When installing the unit on a fixer, Pan/Tilt unit, etc., make sure to install it firmly using a rotation-preventing hole to prevent fall.
- To prevent fall, connect the unit to a section with sufficient strength (ceiling slab or channel) using a fall prevention wire such as a wire chain and the like. Use the black screw on the back of the unit for installation. Pay utmost attention to the length of the wire, too.
- Specified screw (M3 × 6 mm)
Never use any screw longer than the specified length as the inside can be damaged.

①

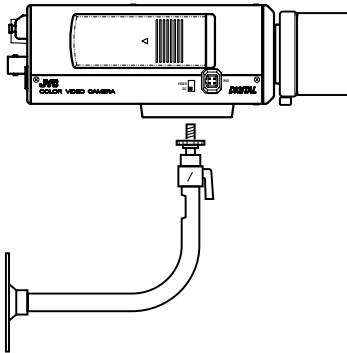

②

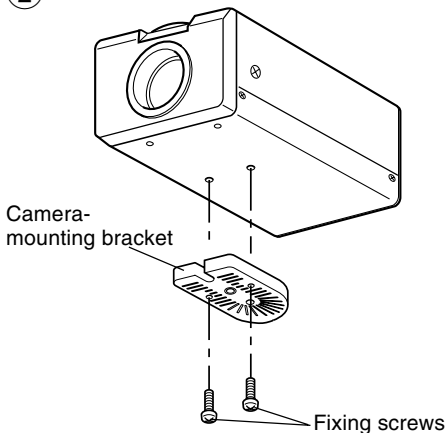

③

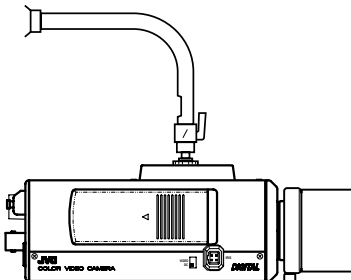

Installation of camera

- Mounting from the bottom
This camera is originally designed to be mounted from the bottom, as shown ①. The hole is standard photographic pan-head screw size (1/4-20 UNC). Example the Fixing unit or Pan/Tilt unit.
- Mounting from the top
Remove the CAMERA MOUNTING BRACKET from the bottom of the camera by removing two fixing screws as shown ②. Attach the CAMERA MOUNTING BRACKET to the top, then mount the camera on the Fixing Unit as shown ③. Make sure that two original screws are used when mounting the CAMERA MOUNTING BRACKET. Be sure to use a 6 mm long locking screw for the camera-mounting bracket.
(This camera is used indoor and under similar conditions.)

CONNECTION/INSTALLATION

Lens adjustment

Connect the camera according to the connection method, turn it on, display an image on the monitor, and check the image. The camera has been factory-adjusted to the best position, but it may need to be adjusted according to the object conditions or combination of lenses. If the image is unnatural, adjust it as follows: (Also read the instruction manual of the lens.)

LEVEL
adjustment

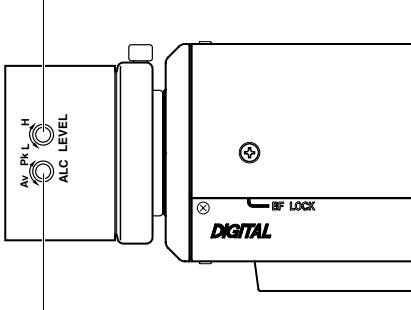

ALC adjustment
(Does not operate.)

MEMO

Note that the lens cannot make ALC adjustments. Make ALC adjustments using the item AVERAGE: PEAK on the menu.

(☞ Page 26)

• LEVEL adjustment

Monitor screen	LEVEL turning direction
Too bright	Counterclockwise (Toward L)
Too dark	Clockwise (Toward H)

MEMO

- If the sensitivity adjustment LEVEL is turned excessively to L, the sensitivity increases because of the AGC function of the camera, and the image looks grainy.
 - If the video iris lens is set to too low a level, malfunction such as the hunting phenomenon, in which the iris opens or closes unintentionally, may occur.
- In such a case, first set LEVEL potentiometer on the lens to the H (iris open) position then adjust it to the optimum level.

Back focus adjustment

■ Back focus adjustment

Be sure to make back-focus adjustments when changing the lens mounting method or using a different lens. If required, adjust it as follows:

- To make accurate back focus adjustments, use the electronic shutter and the ND filter, and carry out the following adjustments in a state where the lens iris is released. (The ND filter acts to reduce the amount of incident light entering the lens evenly over the entire wavelength band.)

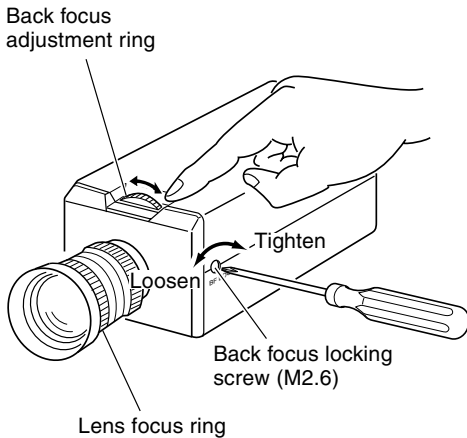

• With a fixed-focus lens

If the focus can not be adjusted correctly by rotating the lens focus ring, adjust the back focus as follows.





1. Loosen the back focus locking screw by turning it counterclockwise (↺) with a screwdriver.
2. Shoot a pattern closely.
3. Turn the lens focus ring to ∞.
4. Turn the back focus adjustment ring to focus at the best point.
5. Tighten the back focus locking screw by turning it clockwise (↻).

• With a zoom lens

If the image is out of focus when zooming (telephoto wide-angle), adjust the camera as follows:

1. Loosen the back focus locking screw by turning it counterclockwise (↺) with a screwdriver.
2. Shoot a comparatively dark scene with thin lines.
3. Set the lens to the maximum telephoto position, and adjust the lens focus.
4. Set the lens to the maximum wide-angle position, and turn the back focus ring to adjust the focus. (Repeat steps 3. and 4. two or three times.)
5. Tighten the back focus locking screw by turning it clockwise (↻).

MEMO

- **LENS FOCUS ADJUSTMENT MODE**
At the time of focus adjustment, press the button  at the side of the unit for at least one second to open the lens iris and to facilitate focusing. At this time, "LENS FOCUS ADJUSTMENT MODE" will be displayed on the monitor screen.
When the adjustment has been completed, press one of the buttons     to cancel focus adjustment mode.
- Focus setting can differ on the colour and on the black and white screen. Make adjustments so that the focus will come to the optimum on both screens.

CONNECTION/INSTALLATION

Auto white balance control adjustment

Each light source has its own colour temperature. Therefore, when the main light source lighting an object is changed, the white balance should be adjusted again by pressing the AWC button.

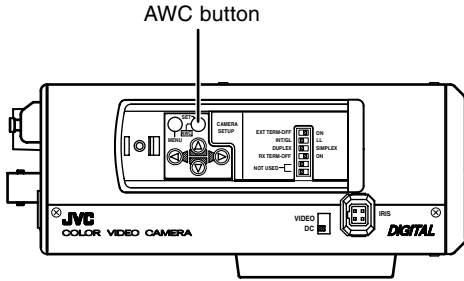

1. Place a white object under the same lighting condition as the object to be shot and zoom in to fill the screen with white.
2. When the AWC button is pressed for approx. one sec., the white balance is adjusted for the object being recorded.
3. During the time when the Auto White function is operated, "AWC OPERATION" is displayed (for approx. 0.5 sec.). When the appropriate white balance is acquired, "AWC OK" is displayed.

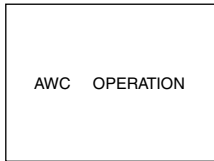

DURING OPERATION

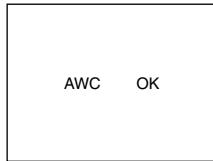

DISPLAYING RESULT

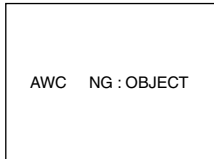

OBJECT ERROR

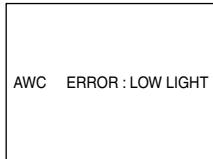

LOW LIGHTING

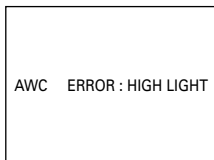

OVER LIGHTING

4. Error message display

● NG : OBJECT

Displayed when there is not enough white colour on an object or the colour temperature is not suitable.

By taking a shot of a white object to fill the screen, adjust the white balance again.

● ERROR : LOW LIGHT

Displayed when the light is low. Increase the illumination then re-adjust the white balance.

● ERROR : HIGH LIGHT

Displayed when the light is too bright. Decrease the illumination then re-adjust the white balance.

MEMO

Even if you press the AWC button, the white balance will not be re-adjusted during the operation in the black-and-white mode.

MENU SETTING

Setting the menu

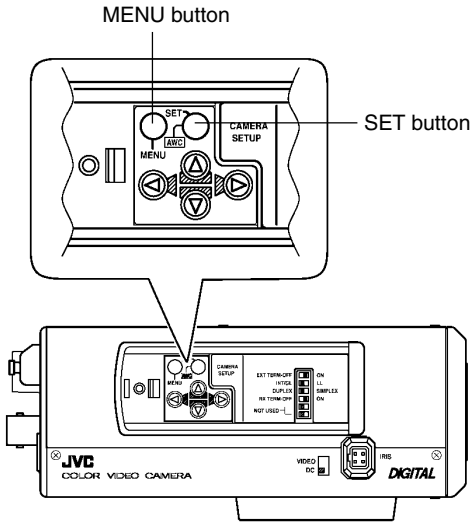

1. Press the MENU button.
The MENU screen is displayed.
2. Set the cursor (>) to a desired sub-menu using the \triangle , ∇ button.

```

--- MENU ---

SYNC ADJUST..
> ALC SETTINGS..
VIDEO ADJUST..
MODE SELECT..
MOTION DETECT..
COMMUNICATION..
MAINTENANCE..
FACTORY SETTINGS..
    
```

3. Press the SET button.
The selected sub-menu screen is displayed.

```

--- ALC SETTINGS ---

> IRIS LEVEL      NORMAL
AVERAGE : PEAK   8 : 2
SHUTTER / ExDR   NORMAL
AGC MODE         20 dB
LOLUX MODE       OFF
SENSE UP         OFF
PRIORITY         ---
BLC              OFF
B&W/COLOUR MODE..
    
```

4. Use the \triangle , ∇ button to set the cursor (>) to a desired item.

```

--- ALC SETTINGS ---

> IRIS LEVEL      NORMAL
AVERAGE : PEAK   8 : 2
SHUTTER / ExDR   NORMAL
AGC MODE         20 dB
LOLUX MODE       OFF
SENSE UP         OFF
PRIORITY         ---
BLC              OFF
B&W/COLOUR MODE..
    
```

5. Change the set value using the \triangleleft , \triangleright button.
Change of the set value displays a change mark (*).

```

--- ALC SETTINGS ---

>*IRIS LEVEL      -5
AVERAGE : PEAK   8 : 2
SHUTTER / ExDR   NORMAL
AGC MODE         20 dB
LOLUX MODE       OFF
SENSE UP         OFF
PRIORITY         ---
BLC              OFF
B&W/COLOUR MODE..
    
```

If you wish to change the set values of another items, repeat items 2. to 5. above.

6. Press the MENU button.
The screen returns to the previous one (MENU screen).
7. Press the MENU button.
The screen returns to the normal screen (quitting the menu display).

* When the setting is executed using the RM-P2580, use a joy stick instead of the \triangle ∇ \triangleleft \triangleright button.

MENU SETTING

The flow of menu screen

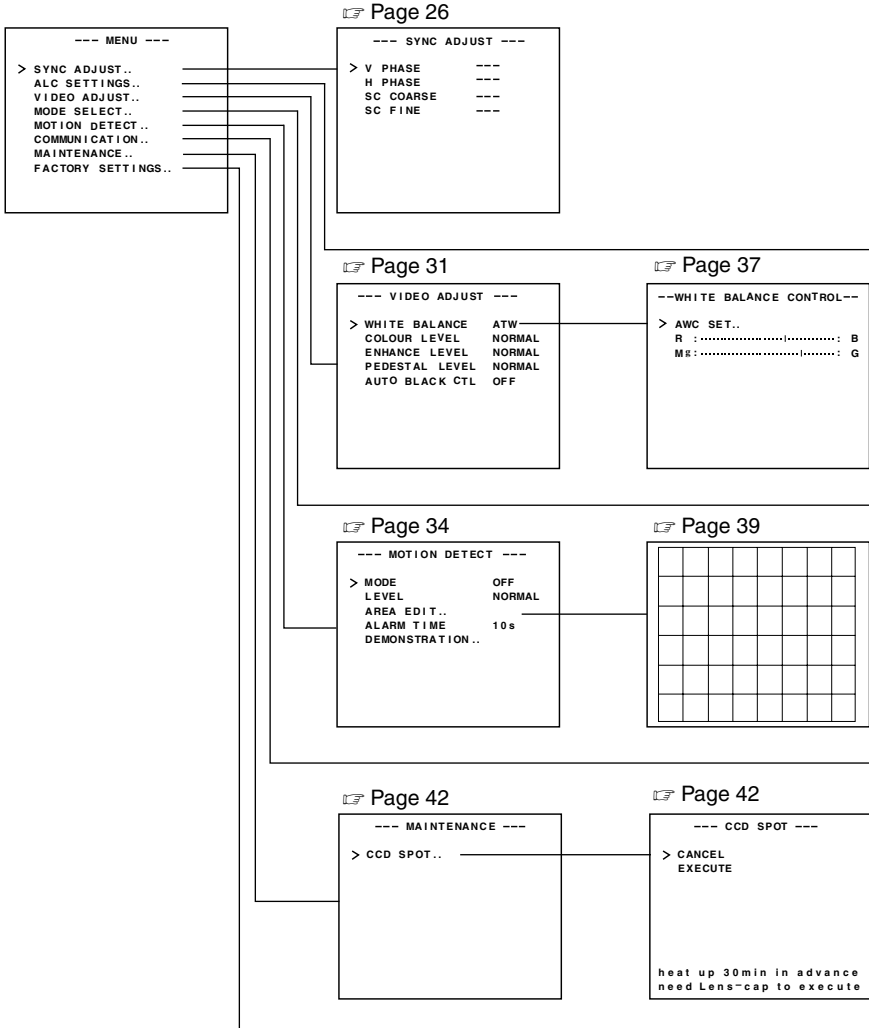

☞ Page 27

```

--- SHUTTER/ExDR ---
> SHUTTER SPEED  1/120
FAST LIMIT      ---
ExDR LEVEL      ---
M.ExDR SPEED    ---

```

☞ Page 26

```

--- ALC SETTINGS ---
> IRIS LEVEL     NORMAL
AVERAGE PEAK   8:2
SHUTTER/ExDR   NORMAL
AGC MODE        20dB
LOLUX MODE     OFF
SENSE UP       OFF
PRIORITY       ---
BLC            OFF
B&W/COLOUR MODE..

```

☞ Page 36

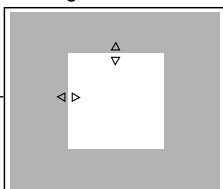

☞ Page 32

```

--- MODE SELECT ---
> CAMERA TITLE EDIT..
REVERSE MODE     OFF
HLI MODE         OFF
ALM.TITLE SIZE   DOUBLE
ALARM COLOUR     WHITE
AUX TERMINAL     (B&W IN)
D.200M MAX       x2

```

☞ Page 30

```

--- B&W/COLOUR MODE ---
> B&W            AUX
AUTO LEVEL       ---

```

☞ Page 35

```

--- COMMUNICATION ---
> STYLE          PTOP
MACHINE ID      ---

```

☞ Page 38

```

--- CAMERA TITLE ---
0123456789-:;.,
ABCDEFGHIJKLMNPO
QRSTUVWXYZ
abcdefghijklmnop
qrstuvwxyz
ÀÔÛÄËÏÒÇÑ
äëïòóäëïòóäëïóú
àèìòùçñßîz

<-WIDE      TELE->
Title Display

```

☞ Page 35

```

--- FACTORY SETTINGS ---
> CANCEL
CLEAR(WITHOUT TITLE)
CLEAR(ALL)

```

MENU SETTING

SYNC ADJUST Screen

This executes the setting regarding synchronization.

Item	Functions and set values	Initial value
V PHASE	This adjusts the vertical synchronization to those of other cameras when a selector switch for the synchronizing system on the side is at LL. (50Hz power region only.) When it is not set to LL, "---" will appear, disabling change the set value. [Set value: -156 to 0 to 156]	0
H PHASE	This adjusts the horizontal synchronization to those of other cameras and systems when a selector switch for the synchronizing system on the side is at INT/GL. When external signals are not input, "---" will appear, disabling change the set value. [Set values: -16 to 0 to 16]	0
SC COARSE	Coarse adjustment of the SC phase in gen-lock operation. The SC phase can be varied by up to 90° in each direction. Adjust with reference to another camera (or system) and together with the SC FINE adjustment. Adjust SC COARSE and SC FINE only after adjusting H PHASE. When it is not set to GL, "---" will appear, disabling change the set value. [Set values: 0°, 90°, 180°, 270°]	0°
SC FINE	Fine adjustment of the SC phase in gen-lock operation. When it is not set to GL, "---" will appear, disabling change the set value. [Set values: 0 to 255]	128

ALC SETTINGS Screen

This makes automatic adjustments according to brightness.

Item	Functions and set values	Initial value
IRIS LEVEL	Adjusts the brightness level of the video signal. <ul style="list-style-type: none"> • To lower the brightness level ... Decrease the value • To raise the brightness level Increase the value [Set values: -5 to NORMAL to 5]	NORMAL
AVERAGE: PEAK	Sets the exposure detection as a ratio of the average value and the peak value. <ul style="list-style-type: none"> • AVERAGE value large: Increase the AVERAGE value when portions other than the highlighted areas of the screen are dark and look corrupted. (Ex. 10:0) • PEAK value large: Increase the PEAK value when halation occurs in the highlighted areas of the screen. (Ex. 5:5) [Set values: 10:0, 9:1, 8:2, 7:3, 6:4, 5:5]	8 : 2

Item	Functions and set values	Initial value
SHUTTER /ExDR	<p>This sets the electronic shutter as well as the ExDR (Extended Dynamic Range). The use of an electronic shutter function enables shooting with proper brightness, as more brightness results in higher shutter speed. The ExDR function allows even the shooting of a subject having different luminous flux density by composing a picture shot at 1/100 sec. shutter speed with a picture shot by a high-speed shutter.</p> <p>NORMAL: This fixes the shutter speed to 1/50. The ExDR does not function.</p> <p>MANUAL: This sets the shutter speed by the item SHUTTER SPEED on the SHUTTER screen. The ExDR does not function. When SENSE UP is functioning, MANUAL cannot be selected. (Not displayed on MÈNU)</p> <p>AUTO: This automatically switches the shutter speed according to brightness. The ExDR does not function. The item FAST LIMIT on the SHUTTER (ExDR) screen sets a maximum shutter speed value.</p> <p>M.ExDR: This is used when shooting a subject with difference in a luminous flux density in the screen under a fixed illumination condition, and so on. During ExDR mode, the item M.ExDR.SPEED on the SHUTTER (ExDR) screen sets the composing high shutter speed. It is possible to set only when the items BLC and SENSE UP are OFF. What's more, the ExDR LEVEL sets the signal level of the composing high-speed shutter.</p> <p>A.ExDR: This is used when the subjects having different luminous flux densities are continuously used night and day in the situation where both indoor and outdoor subjects are mixed in existence, and so forth. During ExDR mode, the composing shutter speed automatically varies according to the contrast of a subject. This is set when shooting the subject with changing brightness. This can be set only when the item BLC is OFF. What's more, the ExDR LEVEL sets the signal level of the composing high-speed shutter.</p> <p>— MEMO —</p> <ul style="list-style-type: none"> • Do not set to A.ExDR when using a manual lens. • When M.ExDR mode or A.ExDR mode is used, the border between a bright part and a dark part can be coloured (cyan, orange, etc.), but this is not a malfunction. • When the SHUTTER/ExDR item is set to M.ExDR or A.ExDR, a flicker can occur under a fluorescent lamp, mercury lamp, etc. However, this occurs by principle of the ExDR function, and therefore this is not a malfunction. 	NORMAL
SHUTTER SPEED	<p>This sets a shutter speed when MANUAL is set. The AUTO, M. ExDR, A. ExDR set value is displayed as “- - -” and cannot be changed [Set values: 1/120, 1/250, 1/500, 1/1000, 1/2000, 1/4000, and 1/10000]</p>	1/120

* When the SHUTTER (ExDR) item is set to NORMAL, the following items (SHUTTER SPEED, FAST LIMIT, ExDR LEVEL, and M.ExDR SPEED) cannot be changed.

MENU SETTING

ALC SETTINGS Screen (Continued)

Item	Functions and set values	Initial value
FAST LIMIT	This sets the fastest value of a shutter speed when AUTO is set. The MANUAL, M. ExDR, A. ExDR set value is displayed as “- -” and cannot be changed. The higher the shutter speed becomes, the more smear phenomenon is emphasized, which is peculiar to the CCD. [Set values: 1/1000, 1/2000, 1/4000, 1/10000, 1/20000, 1/40000, 1/100000]	1/100000
ExDR LEVEL	This sets the signal level of the composing high-speed shutter during ExDR mode. This is set according to the brightness of a subject. When using M.ExDR, be sure to set M.ExDR SPEED in advance. When the SHUTTER/ExDR item is set to MANUAL or AUTO, “- -” appears, disabling setting. To give priority to the low-brightness parts of the subject... increase the value To give priority to the high-brightness parts of the subject... decrease the value [Set values: -5 to NORMAL to 5] — MEMO — • In the case of a subject with a large difference in the luminous flux density, sometimes images do not change even if ExDR LEVEL is varied. However, this occurrence is a peculiarity of the unit and is not a malfunction.	NORMAL
M.ExDR SPEED	This sets the composing high shutter speed when ExDR is set to M.ExDR. Set the shutter speed in order that a subject with a high luminous flux density (outdoor, etc.) may come out most clearly. This is displayed as “- -” during MANUAL, AUTO or A. ExDR and cannot be set. [Set values: 1/500, 1/1000, 1/2000, 1/4000, 1/10000, 1/20000]	1/4000
AGC MODE	This sets a maximum gain of the AGC (Automatic Gain Control). OFF: When the AGC function is not used. 10dB: When luminous energy is insufficient. 20dB: When luminous energy is extremely insufficient. SUPER: When brightness is insufficient even when it is set to 20dB. • If the gain is increased, the screen gets rough in a dark place. • If it is set to SUPER, it can sometimes consume operation time to cope with a drastic level change. • When the item “B&W” is set to “AUTO”, [SUPER] is displayed when the item “AGC MODE” is set to “SUPER”, and [20dB] is displayed for other settings. Increase the gain up to the value displayed.	20dB
LOLUX MODE	Used when brightness is low even when setting the AGC MODE. (Functions regardless of the AGC MODE setting.) OFF: LOLUX MODE is off ON: LOLUX MODE is on (+ 6dB)	OFF
SENSE UP	This item makes up a sensitivity should be heightened automatically when a subject becomes dark. In case of the X32 AUTO, the sensitivity is automatically heightened up to 32 times continuously as compared with standard. As the sensitivity becomes higher, the shutter speed becomes lower, resulting in unnatural motion. If SHUTTER/ExDR is set to MANUAL or the M.ExDR, “- -” will appear, disabling the SENSE UP function. [Set values: OFF, X2 AUTO, X4 AUTO, X8 AUTO, X16 AUTO, X32 AUTO] — MEMO — • When the magnification of SENSE UP is enhanced, the screen can become coarse or whitish, or whitish flaws can emerge sometimes, but this is not abnormal. • When the item SENSE UP is set other than to OFF, a flicker can occur under a fluorescent lamp, mercury lamp, etc. However, this occurs by principle of SENSE UP, and therefore this is not a malfunction.	OFF

Item	Functions and set values	Initial value
<p>PRIORITY</p>	<p>This item sets the order in which the AGC and slow shutter speed decrease function when the object brightness becomes low.</p> <p>If B&W item of the B&W/COLOUR mode is set to AUTO, and the AGC MODE item or the SENSE UP item is set to OFF, “- - -” will appear, disabling any setting.</p> <p>MOTION: Priority is given to motion. This is suitable to a subject with quick motion, since the AGC (automatic gain control) functions with priority when the subject becomes dark.</p> <p>PICTURE: Priority is given to image. When the subject becomes dark, SENSE UP (sensitivity goes up) functions with priority, offering suitability that gives priority to image.</p>	<p>MOTION</p>
<p>BLC</p>	<p>Sets the backlight compensation function. Set when a bright light source, etc. is placed in the same direction as the subject.</p> <p>If the item SHUTTER/ExDR is set to the M.ExDR or the A.ExDR, “- - -” will appear, and the BLC does not function.</p> <p>OFF: The backlight compensation function does not work.</p> <p>AREA 1 to AREA 4: When the SET button is pressed, the fixed light metering areas are displayed. Select one of the four types. (Indicated positions on the screen are rough guides. Execute required settings after checking and confirming the functions on actual images.)</p> <div data-bbox="325 970 796 1145" style="text-align: center;"> <p>The diagram illustrates five different light metering area configurations for the BLC function. Each configuration is shown as a square frame with a specific shaded area inside. Above each frame is the label 'Light metering area'. Below each frame is its corresponding name: OFF, AREA 1, AREA 2, AREA 3, and AREA 4.</p> <ul style="list-style-type: none"> OFF: An empty square frame. AREA 1: A square frame with a shaded area in the top-left corner. AREA 2: A square frame with a shaded area in the center. AREA 3: A square frame with a shaded area in the top-right corner. AREA 4: A square frame with a shaded area in the bottom-right corner. </div> <p>* The indicated position on the screen should be used as a rough guide.</p> <p>EDIT 1 to EDIT 2: When the SET button is pressed, the user light metering areas are displayed. Select one of the two types.</p> <p> “BLC EDITTING Screen” on page 36.</p>	<p>OFF</p>

MENU SETTING

ALC SETTINGS Screen (Continued)

Item	Functions and set values	Initial value
B&W COLOUR MODE ..	This function sets the colour modes to colour or B&W. When switching the mode between “colour” and “B&W” is carried out, the focus may be dislocated. In such a case adjust the focus again.	
B&W	<p>Switches the mode from colour to B&W and visa-versa.</p> <p>OFF : Turns the B&W mode switching function off.</p> <p>ON : Sets the camera permanently to B&W mode.</p> <p>AUTO : The camera automatically switches to Colour mode when the object is bright and B&W mode when it is dark. (☞ Page 40)</p> <p>AUX : B&W/COLOUR switching is carried out according to the signal input from the AUX terminal. (☞ Page 41)</p> <p>— MEMO —</p> <ul style="list-style-type: none"> • If AUTO is selected as the B&W item, the B&W/COLOUR setting can be switched as appropriate according to the brightness of the object, but illumination and screen conditions may make this impossible. Moreover, when you use infrared illumination, if the subject excessively reflects, a B/W screen can switch to a colour screen. To make absolutely certain of B&W/COLOUR switching, set to AUX and input the control signal to the AUX terminal. • If AUX is selected as the B&W item, the AUX TERMINAL item is automatically set to B&W IN. If this changes to anything other than AUX, the AUX TERMINAL item reverts to the value set before the change was made. (☞ Page 33.) 	AUX
AUTO LEVEL	<p>When the “B&W” function is set to “AUTO”, this function sets the signal level of the object at which the camera will automatically switch to B&W mode.</p> <p>LOW : Switches to B&W mode when the signal level of the object indicates low illumination.</p> <p>NORMAL: Switches to B&W mode when the signal level of the object indicates medium illumination.</p> <p>HIGH : Switches to B&W mode when the signal level of the object indicates high illumination.</p> <p>— MEMO —</p> <p>When the item “B&W” is set to other than AUTO, “- - -” is displayed and the settings to the item “LEVEL” cannot be varied.</p>	NORMAL

VIDEO ADJUST Screen



Adjustments are made on video signals.

Item	Functions and set values	Initial value
WHITE BALANCE	<p>Selects the white balance adjustment function. The white balance can be adjusted manually or automatically for light within the colour temperature range of 2500K to 8000K.</p> <ul style="list-style-type: none"> • ATW: Auto-Tracking White Balance mode. This automatically adjusts the white balance. • AWC: Auto White Balance Controll mode. When the SET button is pressed, the adjustment screen appears. (See page 37.) <p>— MEMO — The “- - -” will appear during operation in the black-and-white mode and any setting cannot be changed.</p>	ATW
COLOUR LEVEL	<p>To adjust the colour level of the video signal.</p> <ul style="list-style-type: none"> • To make colours lighter ... Decrease the value • To make colours darker ... Increase the value <p>[Set values: -5 to NORMAL to 5]</p> <p>— MEMO — The “- - -” will appear during operation in the black-and-white mode and any setting cannot be changed.</p>	NORMAL
ENHANCE LEVEL	<p>To adjust the contour enhancing level of the video signal.</p> <ul style="list-style-type: none"> • To make the picture quality harder ... Increase the value • To make the picture quality softer ... Decrease the value <p>[Set values: -5 to NORMAL to 5]</p>	NORMAL
PEDESTAL LEVEL	<p>To adjust the pedestal level of the video signal.</p> <ul style="list-style-type: none"> • To brighten picture ... Increase the value • To darken picture ... Decrease the value <p>[Set values: -5 to NORMAL to 5]</p>	NORMAL
AUTO BLACK CTL	<p>This is set when it is difficult to view a dark part of the image even if gain is boosted by the AGC (automatic gain control).</p> <p>ON: When a black level of the image signal is low, a pedestal level that becomes the standard of black is automatically elevated, making it easier to view a dark part.</p> <p>OFF: AUTO BLACK does not function.</p> <p>— MEMO —</p> <ul style="list-style-type: none"> • When PEDESTAL LEVEL is set to 5, no function can take place even if AUTO BLACK CTL is ON. • When AGC MODE is set to OFF, no function can take place even if AUTO BLACK CTL is ON. 	OFF

MENU SETTING

MODE SELECT Screen

Titles, image reversion, etc., are set.

Item	Functions and set values	Initial value
CAMERA TITLE EDIT	Bring up the CAMERA TITLE, EDIT screen. (☞ Page 38)	—
REVERSE MODE	Settings are executed for image reversion. OFF: Image does not reverse. U-D: Up and down of the image are reversed. R-L: Left and right of the image are reversed. ALL: Up and down and left and right of the image are reversed.	OFF
HLI MODE	The highlighted part of the image is made black to make the surroundings of the highlighted part better visible. Set to HIGH when there are many highlighted parts. [Set values: OFF, LOW, MIDDLE, HIGH]	OFF
ALM.TITLE SIZE	Set the size of the characters displayed in the case of alarms. <div style="display: flex; justify-content: space-around; align-items: center;"> <div style="text-align: center;">  <p>NORMAL</p> </div> <div style="text-align: center;">  <p>DOUBLE</p> </div> </div>	DOUBLE
ALARM COLOUR	This sets the colour of an alarm title. [Set values: WHITE, GREEN, CYAN, YELLOW] — MEMO — In the ALARM mode, the colour of camera title appears in the ALARM COLOUR set.	WHITE

Item	Functions and set values	Initial value
AUX TERMINAL	<p>For setting the signal input or output of the AUX terminal.</p> <p>MOTION: A signal is output if there is a change in the area set on the MOTION DETECT screen.</p> <p>B&W OUT: A signal is output when the camera switches to B&W or Colour mode.</p> <p>B&W IN: Set to this position when inputting the B&W/Colour switching control signal to the AUX terminal. (☞ Page 11, 30.)</p> <p>— MEMO —</p> <ul style="list-style-type: none"> • In setting B&W OUT, if you use an infrared illuminator in link motion, hunting can occur. To prevent this, we recommend that you link in motion this unit and the infrared illuminator, etc., by control signals after setting to B&W IN. • If the B&W item is set to AUX, the AUX TERMINAL item changes to [B&W IN] and can not be changed. 	(B&W IN)
D.ZOOM MAX	<p>This function sets the maximum zoom ratio of the electronic zooming. [Set values: x1, x2, x4, x6, x8, x10]</p> <p>— MEMO —</p> <ul style="list-style-type: none"> • The electronic zoom function can only be used by the communication command of exclusive controllers (RM-P2580, etc.). • Note Picture quality deteriorates under electronic zooming as it is accompanied by digital image processing. • When the electronic zoom magnification ratio is increased, there may be blurring in the upper center left of the screen. This is a characteristic of the main unit and is not a malfunction. 	x2

MENU SETTING

MOTION DETECT Screen

Settings are executed about the motion detecting function that emits alarm signals when there exists any motion in the image. Alarm signals are output from the auxiliary terminals on the back.

Item	Functions and set values	Initial value
MODE	This sets ON/OFF of motion detecting function. OFF: Motion detecting function does not work. ON: Motion detecting function works.	OFF
LEVEL	This sets the level that detects motion. If the item MODE is set to OFF, “- - -” will appear, and settings cannot be changed. To function with large signal level change...decrease the value To function with small signal level change...increase the value [Set values: -5 to NORMAL to 5]	NORMAL
AREA EDIT	This sets the range in which the motion detecting function works. (☞ Page 39)	-
ALARM TIME	This sets the output time of the alarm signal output of AUX terminal as well as “ALARM” display on the screen when motion is detected. If the item MODE is set to OFF, “- - -” will appear, and settings cannot be changed. [Set values: OFF, 5s, 6s, 7s, 8s, 9s, 10s, 15s, 20s, 30s, 1min] — MEMO — Even when the ALARM TIME item is set to OFF, an alarm signal is output from the AUX terminal for about 500ms, and “ALARM” is not displayed on the screen.	10s
DEMONSTRATION	This is used when checking and confirming the set motion detecting function. The detection area is shown in gray. (☞ Page 39)	-

COMMUNICATION Screen

Settings are made for the control signal-connecting terminals on the back.
If the setting is changed, be absolutely sure to switch on the power again.

Item	Functions and set values	Initial value
STYLE	This sets a communication system according to the system used. P TO P (Point to point) This is set when a remote control unit controls a camera. M.DROP (Multi-drop) This is set when a remote control unit controls a plural number of cameras.	P TO P
MACHINE ID	This is set when the STYLE item is set to M.DROP. This is the number that identifies individual cameras in a group. No proper function can be realized if an ID number is repeated within a system. A combined use with the RM-P2580 necessitates the setting together with the video input number of the RM-P2580. If the item STYLE is set to P TO P, “- - -” will appear, and settings cannot be changed.	- - -

MAINTENANCE Screen

White spot compensation is performed.

Item	Functions and set values	Initial value
CCD SPOT	The white spots on the screen, which are characteristic for CCDs can be reduced.  Page 42 “White Spot Compensation”	-

FACTORY SETTINGS Screen

Set values are returned to initial values.

Item	Functions and set values	Initial value
FACTORY SETTINGS	The values set on the menu are returned to initial values. CANCEL : No return to the initial value. CLEAR : Returns set values except titles to the (WITHOUT TITLE) initial value. CLEAR (ALL) : Returns all set values including titles to the initial value. Select respective set value and press the SET button. Then, “DATA CLEARED” will appear for about 3 seconds. Be sure not to switch off the power while the display is still on. — MEMO — However, when FACTORY SETTINGS by means of transmitted commands, the contents of the COMMUNICATION menu do not return to the factory settings.	-

MENU SETTING

BLC EDITTING Screen

It is possible to set freely the light metering area for backlight compensation. The 2 screens of EDIT1 and EDIT2 can be set.

--- ALC SETTINGS ---	
IRIS LEVEL	NORMAL
AVERAGE : PEAK	8 : 2
SHUTTER / ExDR	NORMAL
AGC MODE	20dB
LOLUX MODE	OFF
SENSE UP	OFF
PRIORITY	MOTION
> BLC	EDIT 1
B&W/COLOUR MODE	

MENU button SET button

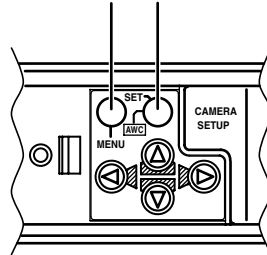

EDIT 1 screen

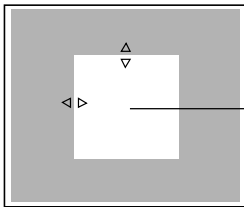

Light metering area

⇕ SET button

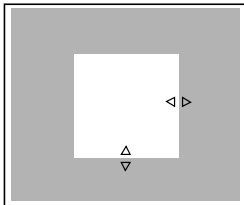

EDIT 2 screen

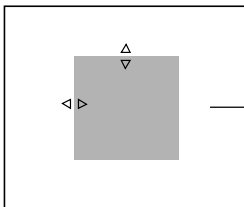

Light metering area

⇕ SET button

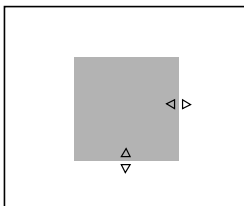

1. Set the item BLC on the ALC SETTING screen to EDIT1.
2. Press the SET button.
The EDIT1 screen is brought up.
3. Set the upper side and left side of the metering area using the button.
The sides having \triangle ∇ \triangleleft \triangleright marks can be changed.
4. Press the SET button.
The changeable sides of the metering area move to the right side and base side.
5. Set the base and right side of the metering area using the button.
If the SET button is pressed once more, the two changeable sides of the metering area return to the top and left sides. (The EDIT2 screen can also be set likewise)
6. Upon completion of setting, press the MENU button.
The screen returns to ALC SETTING SCREEN.

* To use the set metering area, set the item BLC to EDIT1 or EDIT2.

* The indicated position on the screen should be used as a rough guide.

Manual Adjustment of White Balance

When automatic adjustment of the white balance results in a “reddish screen”, etc., adjust the white balance manually.

MENU button SET button

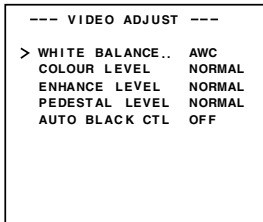
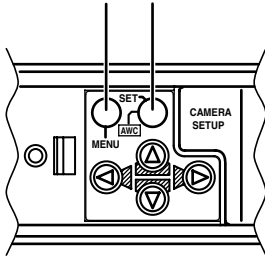

VIDEO ADJUST screen

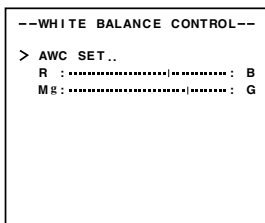

WHITE BALANCE CONTROL screen

1. Set the WHITE BALANCE item on the VIDEO ADJUST screen to AWC and press the SET button.
 - * The WHITE BALANCE adjustment screen appears on the monitor.
 - * Select AWC SET, and press the SET button. AWC (white balance adjustment) is performed, and the WHITE BALANCE CONTROL screen appears on the monitor.
2. Select the hue to be adjusted. (R/B or Mg/G)
 - Press the or .
3. Adjust the hue.
 - Press the or .
 - * The “|” indicator moves in accordance with the setting. When a setting is changed, the “+” mark appears at the original position.
4. Concluding manual white balance adjustment.
 - Pushing the MENU button returns the screen to VIDEO ADJUST.

MEMO

If the mode is changed from colour to black-and-white during the colour phase adjustment on the WHITE BALANCE CONTROL screen, the VIDEO ADJUST screen will be brought back. At this time, any adjusted value will not be saved.

Setting the MOTION DETECT Function

It is possible to set freely the area where MOTION DETECTING functions.

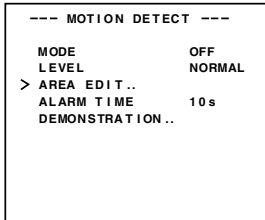



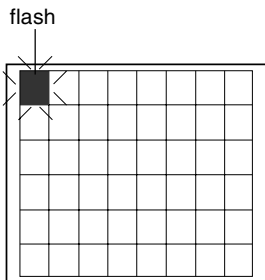

MOTION DETECT screen

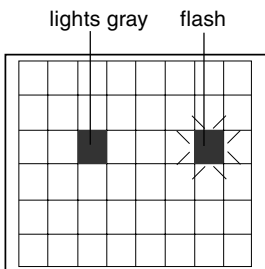

Setting screen



1. Select the item AREA EDIT on the MOTION DETECT screen.
2. Press the SET button.
The setting screen is brought up.
3. Select the area not subject to detection using the     button.
The area flashing ON and OFF in black and white moves.
4. Press the SET button.
The area not subject to detection is set, and it turns gray (lights up).
To cancel the set area, press the SET button again.
5. Repeat items 3 and 4 above.
6. Upon completion of setting, press the MENU button.
The screen returns to the MOTION DETECT menu.

MEMO

- Indicated positions on the screen are rough guides.
Be sure to check and conform the positions on the actual screen.
- * It is possible to check and confirm the set areas on the DEMONSTRATION screen.
The detection area is shown in gray.
- The MOTION DETECT function does not work for about 5 seconds after exiting MENU.

The motion detector is not a feature to prevent theft, fire, etc. Even if an accident should occur resulting in damage, we do not accept any liability.

Output of Black-White/Colour switching signal

It is possible to output black-white/colour switching signal from the AUX terminal on the back of this unit. Perform the following settings.

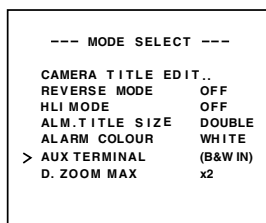
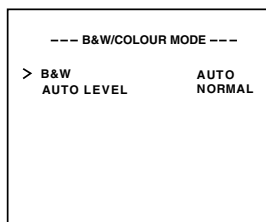
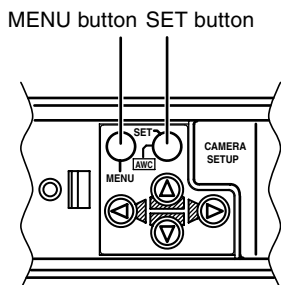

CAUTION:

When you use near infrared ray illuminations, use a lens that is compatible with the near infrared ray illuminations. Any lens other than the compatible one can result in out-of-focus due to such characteristics.

■ Set the B&W Item to AUTO.

1. Select the B&W/COLOUR MODE item on the ALC SETTING screen.
2. Press the SET button.
The B&W/COLOUR MODE screen appears.
3. Press either the button or the button and select the B&W item.
4. Press either the button or the button and set to "AUTO".
5. Upon completion of setting, press the MENU button twice.
Then, the MAIN MENU screen is brought back.

■ Set the AUX TERMINAL Item to B&W OUT.

1. Select MODE SELECT on the MAIN MENU screen.
2. Press the SET button.
The MODE SELECT screen appears.
3. Press either the button or the button and select the AUX TERMINAL item.
4. Press either the button or the button and set to "B&W OUT".
5. Upon completion of setting, press the MENU button twice.
 - Then, the normal screen is brought back.

MEMO

- When you use infrared illumination, if the subject excessively reflects, a B/W screen can switch to a colour screen.
To perform switching with higher accuracy, we recommend that you use it by the setting mentioned in [Control by Black-White/Colour Switching Signal From the Outside], referring to Page 41.

Control by Black-White/Colour switching signal from the outside

Carry out the following setting when you link in motion the black-white/colour switching of this unit and infrared illumination, etc., using the switching signal from the outside control device.

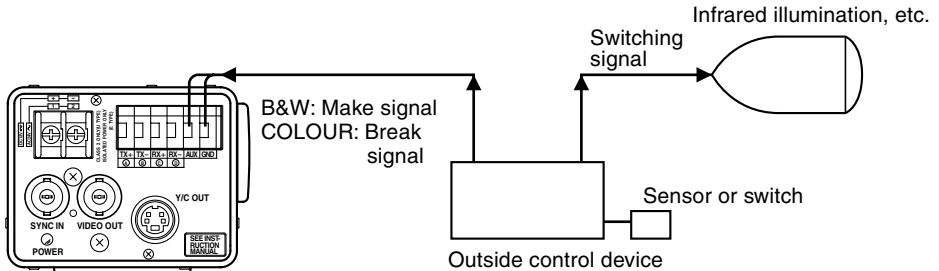

It is requested that you consult our JVC dealer about connecting devices, etc.

MENU button SET button

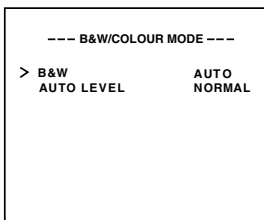
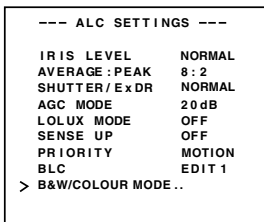
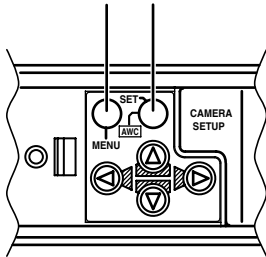

■ Set the B&W item to AUX.

1. Select B&W/COLOUR MODE on the ALC SETTING screen.
2. Press the SET button.
 - The B&W/COLOUR MODE screen appears.
3. Press either the button or the button and select the B&W item.
4. Press either the button or the button and set to "AUX".
 - Then, the AUX TERMINAL item on the MODE SELECT screen is automatically set to (B&W IN). Refer to Page 33.
5. Upon completion of setting, press the MENU button.
 - Then, the ALC SETTING screen is brought back.

CAUTION:

When you use near infrared ray illuminations, use a lens that is compatible with the near infrared ray illuminations. Any lens other than the compatible one can result in out-of-focus due to such characteristics.

White spot compensation

CCDs have the general characteristic that white spots appear on the screen when the CCD is operated at high temperatures or when they are used with a slow shutter speed.

This unit has a built-in white spot compensation function to reduce these white spots.

(The number and the size of the white spots changes according to the use temperature, the shutter speed, etc. Furthermore, there is a limit on the number of white spots that can be compensated.)

Operation method

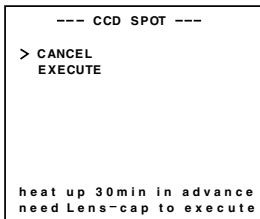
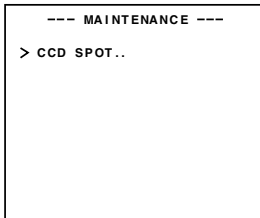

- 1. Attach a lens cap or similar.**
 - Prevent entry of light to the CCD.
 - Switch on the camera power supply and wait for at least 30 minutes.
- 2. Display the MAINTENANCE screen.**
 - Confirm that the cursor (>) is at the item CCD SPOT.
- 3. Press the SET button.**
 - The CCD SPOT screen will be displayed.
 - If you do not want to perform white spot compensation, move the cursor (>) to CANCEL and press the SET button.
- 4. Move the cursor (>) to EXECUTE.**
- 5. Press the SET button.**
 - White spot compensation will operate. ("SPOT SCAN OPERATION" is displayed during operation.)
- 6. Confirm the display.**
 - When white spot compensation has been performed correctly, "SPOT SCAN OK" is displayed for about 5 seconds, and then return is made to the CCD SPOT screen.
 - When "SPOT SCAN ERROR: HIGH LIGHT" is displayed, check that no light enters into the CCD.
- 7. Press the MENU button.**
 - Return to the MENU screen will be made.

OTHERS

Specifications

Image pickup device:	1/3 type IT CCD, 752 (H) × 582 (V)
Synchronization method :	Internal, Line lock, Full Genlock
Scanning frequency:	(H) 15.625 kHz, (V) 50 Hz
Resolution:	480 TV lines (H)
VIDEO OUT:	Composite video signal 1 V (p-p), 75 Ω (BNC)
Y/C OUT:	Y: 1.0 V (p-p), 75 Ω C: 0.3 V (p-p), 75 Ω
Video S/N ratio:	50 dB (AGC OFF)
Minimum required illumination:	0.9 lx (50 %, F1.2, AGC 20 dB) 0.45 lx (50 %, F1.2, AGC 20 dB, LOLUX MODE) 0.45 lx (25 %, F1.2, AGC 20 dB) 0.23 lx (25 %, F1.2, AGC 20 dB, LOLUX MODE) 0.03 lx (50 %, F1.2, AGC 20 dB, B&W MODE) 0.015 lx (50 %, F1.2, AGC 20 dB, LOLUX MODE, B&W MODE) 0.015 lx (25 %, F1.2, AGC 20 dB, B&W MODE) 0.03 lx (50 %, F1.2, AGC 20 dB, SENSE UP × 32) 0.014 lx (50 %, F1.2, AGC 20 dB, LOLUX MODE, SENSE UP × 32)
Communication:	RS-422A or RS-485 (switchable) 9600 bit/s
Lens mount:	C/CS mount
Power supply and power consumption:	TK-C1430E AC 24 V ~ 50 Hz/60 Hz, DC 12 V $\bar{\bar{}}$ 530 mA TK-C1431EG AC 220 V - AC 240 V ~, 50 Hz/60 Hz, 75 mA
Ambient temperature:	-10 °C to 50 °C (operation) 0 °C to 40 °C (recommended)
Mass:	TK-C1430E 620 g TK-C1431EG 840 g
Accessory:	Instructions 2 Ferrite core 1 4P plug 1

DIMENSIONS (Unit: mm)

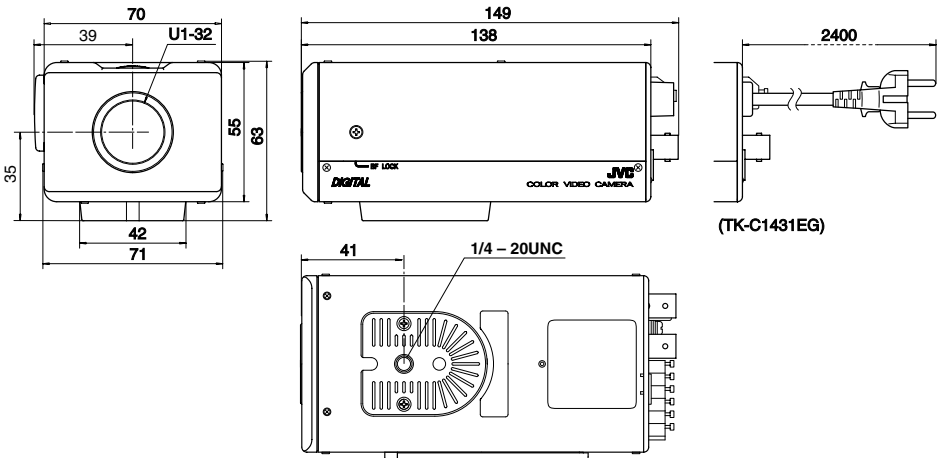

Design and specifications are subject to change without notice.

JVC®

JVC® is a registered trademark owned by Victor Company of Japan, Limited.

JVC® is a registered trademark in Japan, the U.S.A., the U.K. and many other countries.

© 2005 Victor Company of Japan, Limited.

Printed in Thailand
LWT0276-001A-H